

PLOT PLAN

LOT 956

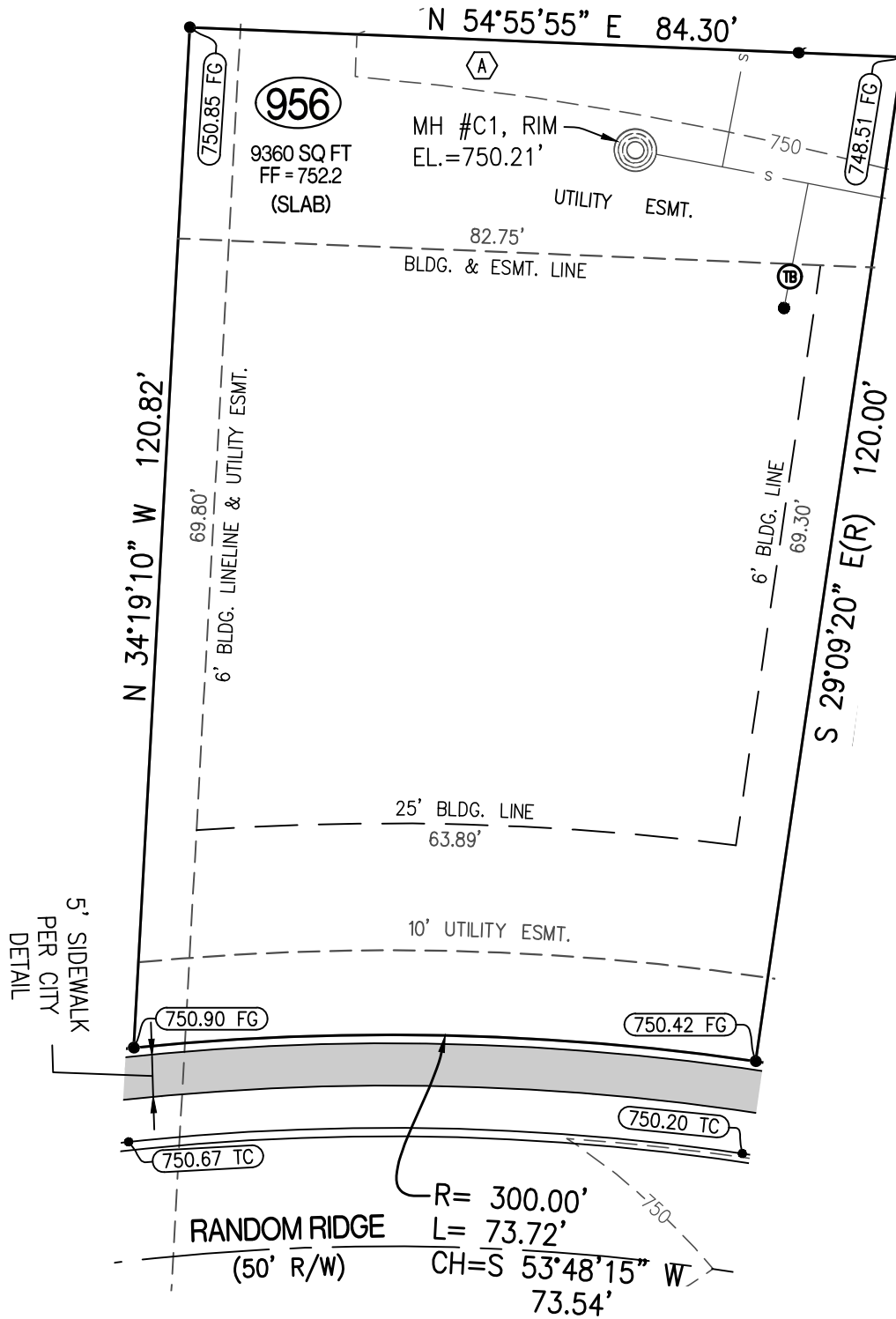
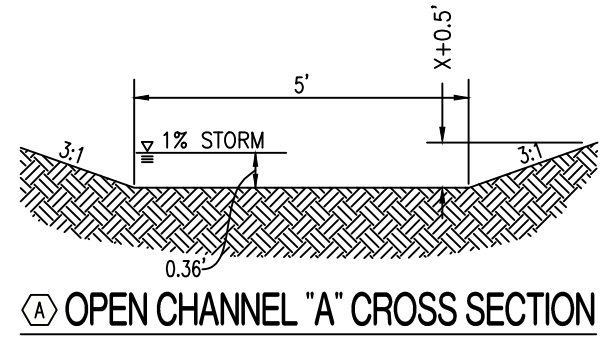

CERTIFICATION:

I HEREBY CERTIFY THAT THE ABOVE LOT WAS SURVEYED UNDER MY DIRECTION. I FURTHER STATE THAT THE ABOVE LOT DOES NOT LIE WITHIN THE 100 YEAR FLOOD PLAIN AS ADOPTED BY THE CITY OF COLUMBIA, MISSOURI.

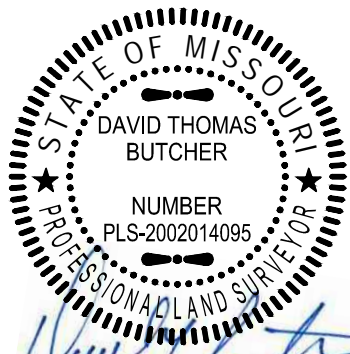

DAVID T. BUTCHER, PLS-2002014095
6/15/2022
DATE

LEGEND:

- 1/2" IRON PIPE OR 1/2" REBAR
- ⊕ PERMANENT MONUMENT
- (R) RADIAL LINE
- s— PROPOSED SANITARY SEWER
- PROPOSED LOCATION OF SEWER LATERAL
- ⊙ PROPOSED SAN. SEWER MANHOLE BASED ON DESIGN PLAN
- (xxx.xx TC) PROPOSED TOP OF CURB EL. BASED ON DESIGN PLAN
- FF = xxx.x MINIMUM FINISHED FLOOR
- ⓑ TRACER BOX

DESCRIPTION:

LOT 956 OF THE VINEYARDS, PLAT No. 9, RECORDED IN PLAT BOOK 56, PAGE 39, LOCATED IN COLUMBIA, BOONE COUNTY, MISSOURI.

CROCKETT
ENGINEERING CONSULTANTS
1000 W. Nifong Blvd., Building 1
Columbia, Missouri 65203
(573) 447-0292
www.crockettengineering.com

CORPORATE NUMBER: 2000151304	
DATE: 5/04/2022	SCALE: 1" =
PROJECT: 041371	DRAWN BY: NDD

THE VINEYARDS, PLAT No. 9
PLOT PLAN LOT 956 SEC. 21 - T48N - R12W COLUMBIA, BOONE COUNTY, MISSOURI
ADDRESS:

