

# PLOT PLAN

## LOT 944

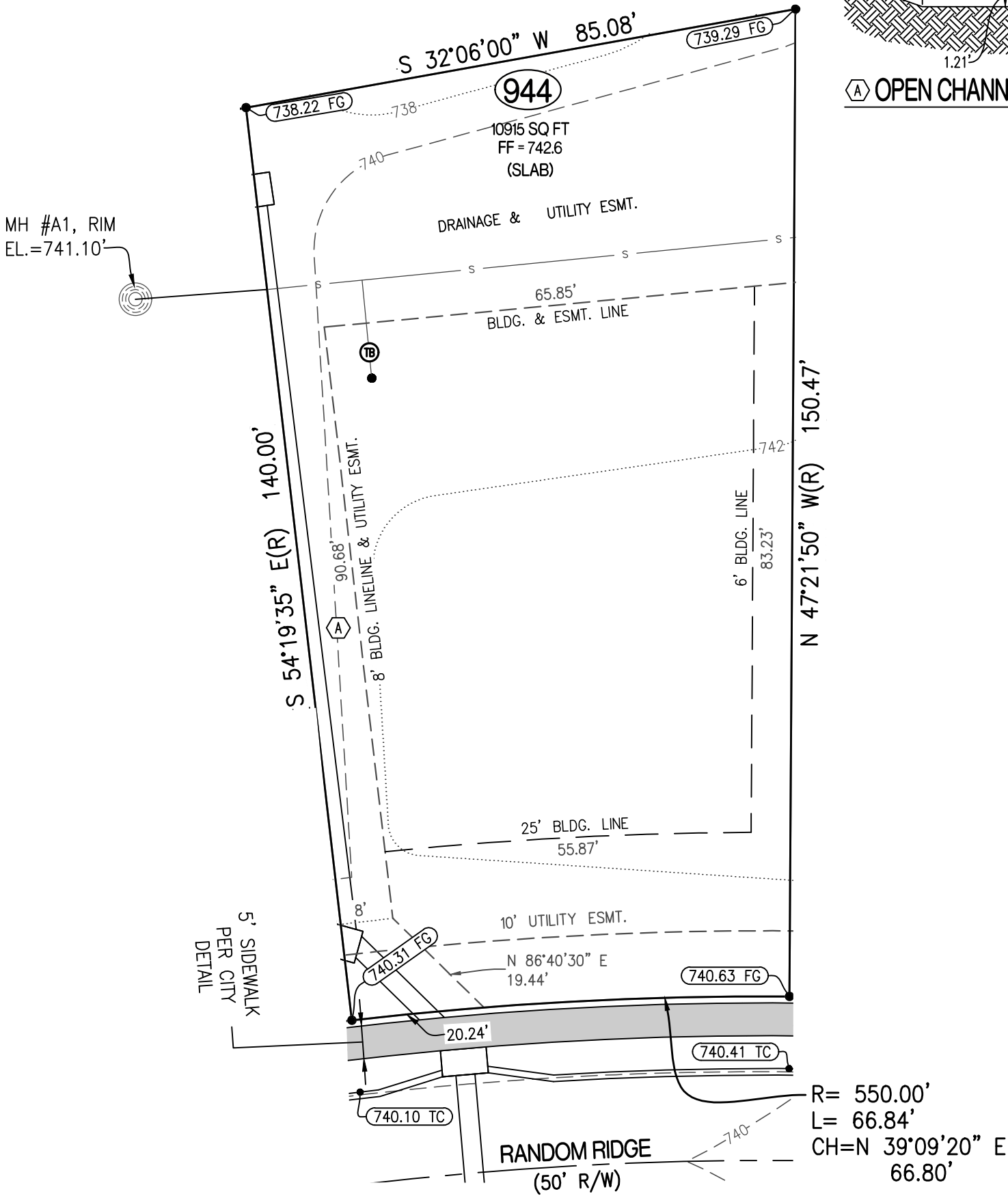
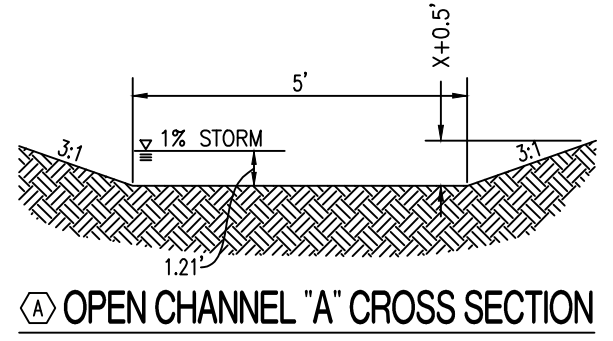

### CERTIFICATION:

I HEREBY CERTIFY THAT THE ABOVE LOT WAS SURVEYED UNDER MY DIRECTION. I FURTHER STATE THAT THE ABOVE LOT DOES NOT LIE WITHIN THE 100 YEAR FLOOD PLAIN AS ADOPTED BY THE CITY OF COLUMBIA, MISSOURI.

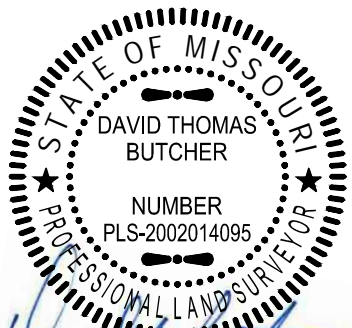

DAVID T. BUTCHER, PLS-2002014095  
6/15/2022  
DATE

### LEGEND:

- 1/2" IRON PIPE OR 1/2" REBAR
- ⊕ PERMANENT MONUMENT
- (R) RADIAL LINE
- s— PROPOSED SANITARY SEWER
- PROPOSED LOCATION OF SEWER LATERAL
- ⊙ PROPOSED SAN. SEWER MANHOLE BASED ON DESIGN PLAN
- (XXX.XX TC) PROPOSED TOP OF CURB EL. BASED ON DESIGN PLAN
- FF = XXX.X MINIMUM FINISHED FLOOR
- Ⓟ TRACER BOX

### DESCRIPTION:

LOT 944 OF THE VINEYARDS, PLAT No. 9, RECORDED IN PLAT BOOK 56, PAGE 39, LOCATED IN COLUMBIA, BOONE COUNTY, MISSOURI.

**CROCKETT**  
ENGINEERING CONSULTANTS  
1000 W. Nifong Blvd., Building 1  
Columbia, Missouri 65203  
(573) 447-0292  
www.crockettengineering.com

CORPORATE NUMBER: 2000151304	
DATE: 5/04/2022	SCALE: 1" = 20'
PROJECT: 041371	DRAWN BY: NDD

<b>THE VINEYARDS, PLAT No. 9</b>
PLOT PLAN LOT 944 SEC. 21 - T48N - R12W COLUMBIA, BOONE COUNTY, MISSOURI
ADDRESS:

